

NR/NRS-X

LM Guide Ultra-heavy Load Type for Machine Tools Model NR/NRS-X

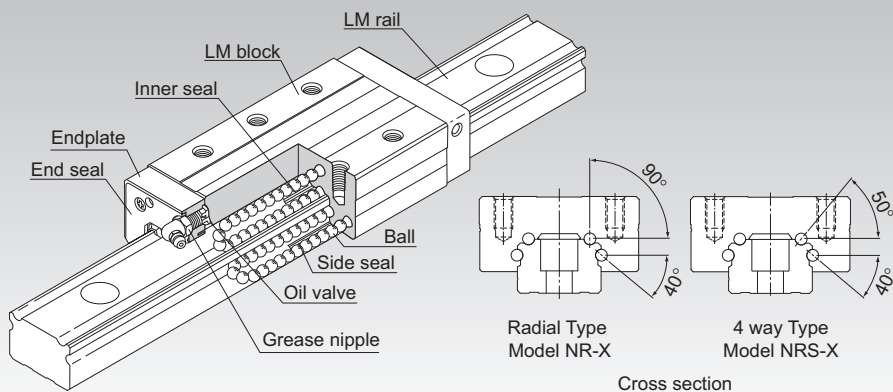

Point of Selection **A1-10**

Point of Design **A1-454**

Options **A1-477**

Model No. **A1-543**

Precautions on Use **A1-549**

Accessories for Lubrication **A24-1**

Mounting Procedure and Maintenance **B1-89**

Equivalent moment factor **A1-43**

Rated Loads in All Directions **A1-59**

Equivalent factor in each direction **A1-61**

Radial Clearance **A1-71**

Accuracy Standards **A1-77**

Shoulder Height of the Mounting Base and the Corner Radius **A1-464**

Permissible Error of the Mounting Surface **A1-470**

Dimensions of Each Model with an Option Attached **A1-491**

Structure and Features

Balls roll in four rows of raceways precision-ground on an LM rail and an LM block, and endplates incorporated in the LM block allow the balls to circulate. The raceways are cut into deep grooves that have a radius closer to that of the balls than in the conventional design, using special equipment and an extremely precise cutting technique. This design allows high rigidity, high vibration/impact resistance and high damping capacity, all of which are required for machine tools, thus making these models capable of bearing ultra-heavy loads.

* Due to the extremely high rigidity of the LM guides used in models NR/NRS-X, the construction does not easily absorb the effects of mounting surface misalignment and installation errors. Where such effects arise, there is a risk of reduced operating life and/or malfunction. Contact THK when considering the use of these products.

[Improved Damping Capacity]

While the machine tool (equipped with NR or NRS) is not cutting a workpiece during operation, the LM Guide travels normally and smoothly. While the machine tool is cutting the workpiece, the cutting force is applied to the LM Guide to increase and the contact area between the balls and the raceway, allowing an appropriate mixture of rolling and sliding motions to be achieved. Accordingly, the friction resistance is increased and the damping capacity is improved.

Since the absolute slip during the rolling and sliding motion is insignificant, it causes little wear and does not affect the service life.

[Highly Rational LM Guide]

The excessively large differential slip occurring in a Gothic-arch groove does not happen with these models. They smoothly travel and achieve high positioning accuracy during fast feeding. During the cutting operation, appropriate slip occurs according to the cutting load, the rolling resistance is increased and the damping capacity is increased. Thus, models NR and NRS are highly rational LM Guides.

[High Rigidity]

To increase the rigidity of the LM block and the LM rail, which may deteriorate the overall rigidity of the LM Guide in the reverse radial and lateral directions, THK made full use of FEM to achieve optimal design within the limited dimensional range.

THK offers two identically sized models with different characteristics, namely the Radial Type Model NR-X and 4 way Type Model NRS-X. Users can select the model that best suits their specifications.

[Ultra-heavy Load]

Since the curvature of the raceway is approximated to the ball diameter, the ball contact area under a load is increased and the LM Guide is capable of receiving an ultra-heavy load.

Types and Features

Models NR-RX/NRS-RX

With this type, the LM block has a smaller width (W) and tapped holes. Used in places where the space for table width is limited.

Specification Table → [A1-228/A1-230](#)

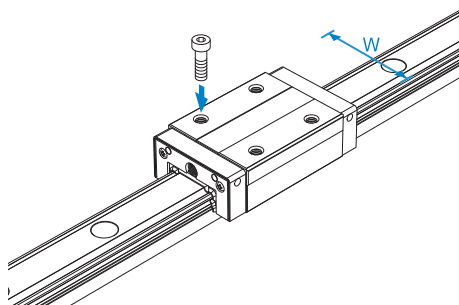

Models NR-LRX/NRS-LRX

The LM block has the same cross-sectional shape as models NR-RX/NRS-RX, but has a longer overall LM block length (L) and a greater rated load.

Specification Table → [A1-228/A1-230](#)

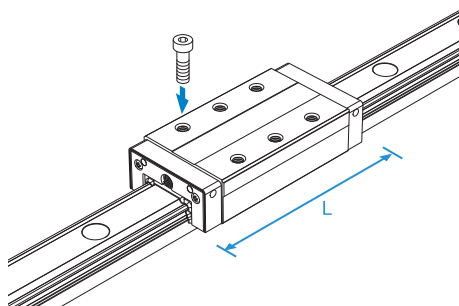

Models NR-CX/NRS-CX

The flange of the LM block has tapped holes.
Can be mounted from the top or the bottom.
Can also be used in places where the table
cannot have through holes for mounting bolts.

Specification Table → [A1-232](#)/[A1-234](#)

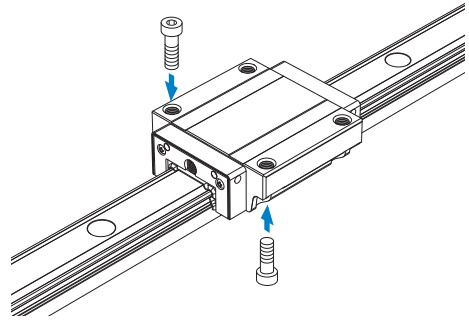

LM Guide

Models NR-LCX/NRS-LCX

The LM block has the same cross-sectional
shape as models NR-CX/NRS-CX, but has a
longer overall LM block length (L) and a greater
rated load.

Specification Table → [A1-232](#)/[A1-234](#)

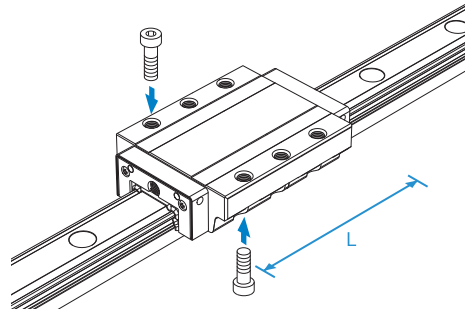

Models NR-R/NRS-R

With this type, the LM block has a smaller width (W) and tapped holes. Used in places where the space for table width is limited.

Specification Table⇒ [A1-228/A1-230](#)

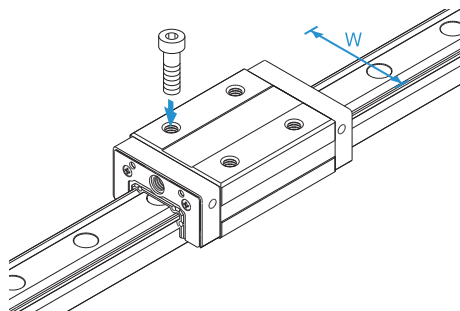

Models NR-LR/NRS-LR

The LM block has the same cross-sectional shape as models NR-R/NRS-R, but has a longer overall LM block length (L) and a greater rated load.

Specification Table⇒ [A1-228/A1-230](#)

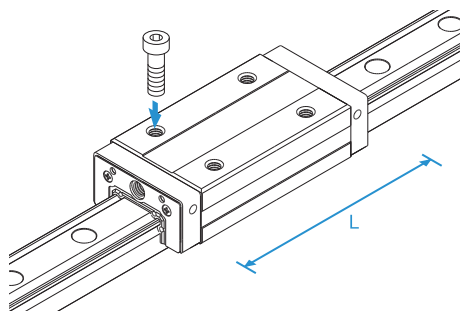

Models NR-A/NRS-A

The flange of its LM block has tapped holes.

Specification Table⇒ [A1-236](#)

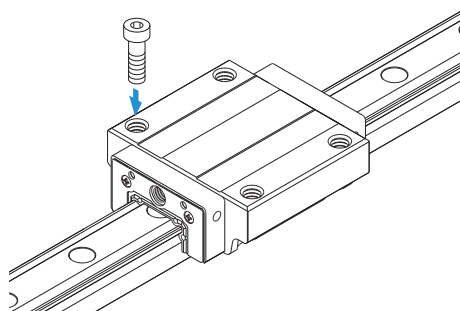

Models NR-LA/NRS-LA

The LM block has the same cross-sectional shape as models NR-A/NRS-A, but has a longer overall LM block length (L) and a greater rated load.

Specification Table⇒ **A1-236**

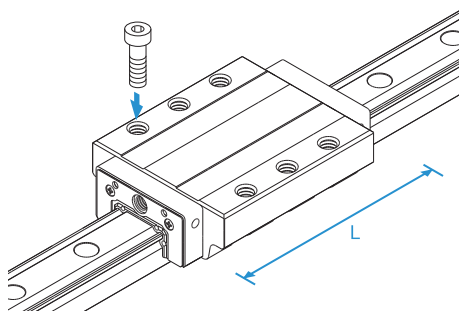

LM Guide

Models NR-B/NRS-B

The flange of the LM block has through holes. Used in places where the table cannot have through holes for mounting bolts.

Specification Table⇒ **A1-238**

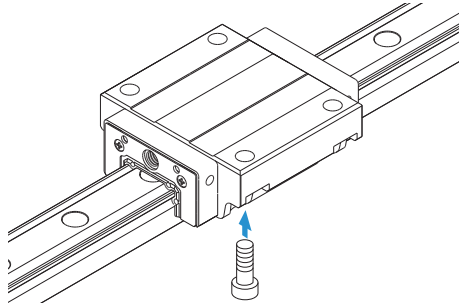

Models NR-LB/NRS-LB

The LM block has the same cross-sectional shape as models NR-B/NRS-B, but has a longer overall LM block length (L) and a greater rated load.

Specification Table⇒ **A1-238**

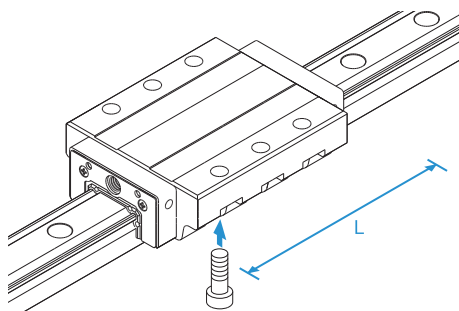

Models NR-RX, NR-LRX, NR-R and NR-LR

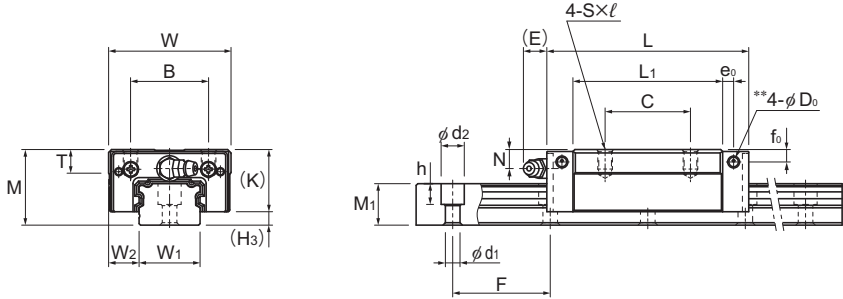

Model NR-RX

Model No.	Outer dimensions			LM block dimensions												Grease nipple	H ₃
	Height	Width	Length	B	C	S×ℓ	L ₁	T	K	N	f ₀	E	e ₀	D ₀			
	M	W	L	B	C	S×ℓ	L ₁	T	K	N	f ₀	E	e ₀	D ₀			
NR 25RX NR 25LRX	31	50	82.8 102	32	35 50	M6×8	61.4 80.6	9.7	25.5	7.8	5.1	12	4.5	3.9	B-M6F	5.5	
NR 30RX NR 30LRX	38	60	98 120.5	40	40 60	M8×10	72.1 94.6	9.7	31	10.3	7	12	6.5	3.9	B-M6F	7	
NR 35RX NR 35LRX	44	70	109.5 135	50	50 72	M8×12	79 104.5	11.7	35	12.1	8	12	6	5.2	B-M6F	9	
NR 45RX NR 45LRX	52	86	138.2 171	60	60 80	M10×17	105 137.8	14.7	40.4	13.9	8	16	8.5	5.2	B-PT1/8	11.6	
NR 55RX NR 55LRX	63	100	163.3 200.5	65	75 95	M12×18	123.6 160.8	17.7	49	16.6	10	16	10	5.2	B-PT1/8	14	
NR 65RX NR 65LRX	75	126	186 246	76	70 110	M16×20	143.6 203.6	21.6	60	19	15	16	8.7	8.2	B-PT1/8	15	
NR 75R NR 75LR	83	145	218 274	95	80 130	M18×25	170.2 226.2	25.3	68	18	17	16	9	8.2	B-PT1/8	15	
NR 85R NR 85LR	90	156	246.7 302.8	100	80 140	M18×25	194.9 251	27.3	73	20	20	16	10	8.2	B-PT1/8	17	
NR 100R NR 100LR	105	200	286.2 326.2	130	150 200	M18×27	223.4 263.4	34.3	85	23	23	10	12	8.2	B-PT1/4	20	

Model number coding

NR35 LRX 2 QZ KKHH C0 +1240L P T - II

Model number

Type of LM block

With QZ Lubricator

Contamination protection accessory symbol (*1)

LM rail length (in mm)

Symbol for LM rail jointed use

Symbol for No. of rails used on the same plane (*4)

No. of LM blocks used on the same rail

Radial clearance symbol (*2)

Normal (No symbol)

Light preload (C1)

Medium preload (C0)

Accuracy symbol (*3)

Normal grade (No Symbol)/High accuracy grade (H)

Precision grade (P)/Super precision grade (SP)

Ultra precision grade (UP)

(*1) See contamination protection accessory on **A1-516** (*2) See **A1-71**. (*3) See **A1-77**.

(*4) See **A1-13**.

Note) This model number indicates that a single-rail unit constitutes one set. (i.e., required number of sets when 2 rails are used in parallel is 2 at a minimum.)

Those models equipped with QZ Lubricator cannot have a grease nipple. When desiring a grease nipple for a model attached with QZ, contact THK.

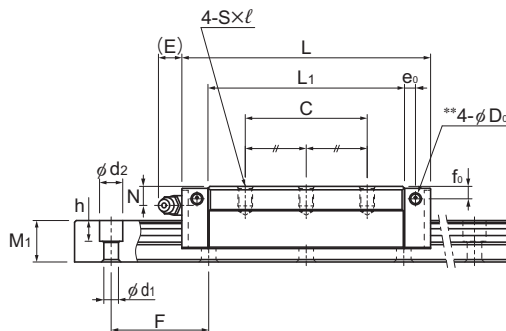

Model NR-LRX

Unit: mm

LM rail dimensions						Basic load rating		Static permissible moment kN•m*						Mass	
Width W ₁ 0 -0.05	W ₂	Height M ₁	Pitch F	d ₁ × d ₂ × h	Length* Max	C kN	C ₀ kN	M _A		M _B		M _C	LM block kg	LM rail kg/m	
								1 block	Double blocks	1 block	Double blocks	1 block			
25	12.5	17	40	6×9.5×8.5	3000	37.1 45.4	68.1 90.8	0.57 0.989	3.04 4.91	0.346 0.597	1.84 2.95	0.703 0.937	0.4 0.5	2.9	
28	16	21	80	7×11×9	3000	54.7 66.9	98.1 130.8	1.71 2.46	5.17 8.34	0.599 1.03	3.13 5.02	1.15 1.53	0.7 0.9	4.2	
34	18	24.5	80	9×14×12	3000	72.4 89.6	124.6 169.1	1.37 2.46	7.38 12.1	0.835 1.49	4.48 7.3	1.74 2.36	1 1.3	6	
45	20.5	29	105	14×20×17	3090	110.2 132	197.6 255.8	2.81 4.87	14.7 23	1.72 2.94	8.95 13.8	3.72 4.81	1.8 2.3	9.5	
53	23.5	36.5	120	16×23×20	3060	141.9 175.1	250.2 338.4	4.22 7.27	21.8 35.9	2.56 4.4	13.2 21.7	5.37 7.27	3.3 4.3	14	
63	31.5	43	150	18×26×22	3000	208.7 268.9	351.7 505.5	6.87 13.8	35 65.4	4.16 8.31	21.2 39.3	8.94 12.9	6 8.5	19.6	
75	35	44	150	22×32×26	3000	271 355	610 800	14.4 25.4	73.3 118	8.91 15.4	44.7 71.4	19.3 25.2	8.7 11.6	24.6	
85	35.5	48	180	24×35×28	3000	336 435	751 972	20.3 34.7	102 160	12.4 21	62.6 96.2	26.8 34.6	12.3 15.8	30.5	
100	50	57	210	26×39×32	3000	479 599	1040 1300	34 47.3	167 238	20.7 29.2	101 146	43.4 54.6	21.8 26.1	42.6	

Note1) The maximum length under "Length*" indicates the standard maximum length of an LM rail. (See [A1-240](#).)

Static permissible moment* 1 block: the static permissible moment with one LM block

Double blocks: static permissible moment when two LM blocks are in close contact with each other

For oil lubrication, be certain to let THK know the mounting orientation and where the LM block piping joint should be attached.

(Mounting orientation: see [A1-12](#), Lubricant: see [A24-2](#))

Total block length L

: The total block length L shown in the table is the length with the dust proof parts, code UU or SS. If other contamination protection accessories or lubricant equipment are installed, the total block length will increase.

(See [A1-491](#) or [A1-512](#))

** A pilot hole for side nipples, when a grease nipple for a model equipped with LaCS or QZ Lubricator is needed.

Pilot holes for side nipples are not drilled through for models other than those stated above.

For grease nipple mount machining, contact THK.

Note2) The basic load rating in the dimension table is for a load in the radial direction. Use Table7 on [A1-59](#) to calculate the load rating for loads in the reverse radial direction or lateral direction.

Models NRS-RX, NRS-LRX, NRS-R and NRS-LR

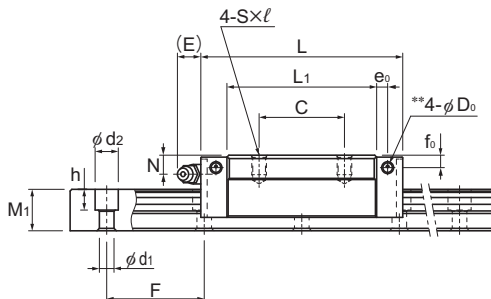
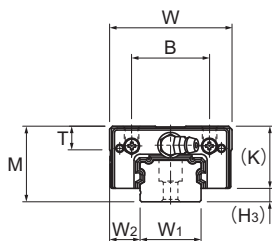

Model NRS-RX

Model No.	Outer dimensions			LM block dimensions												Grease nipple	H ₃
	Height	Width	Length	B	C	S×ℓ	L ₁	T	K	N	f ₀	E	e ₀	D ₀			
	M	W	L														
NRS 25RX NRS 25LRX	31	50	82.8 102	32	35 50	M6×8	61.4 80.6	9.7	25.5	7.8	5.1	12	4.5	3.9	B-M6F	5.5	
NRS 30RX NRS 30LRX	38	60	98 120.5	40	40 60	M8×10	72.1 94.6	9.7	31	10.3	7	12	6.5	3.9	B-M6F	7	
NRS 35RX NRS 35LRX	44	70	109.5 135	50	50 72	M8×12	79 104.5	11.7	35	12.1	8	12	6	5.2	B-M6F	9	
NRS 45RX NRS 45LRX	52	86	138.2 171	60	60 80	M10×17	105 137.8	14.7	40.4	13.9	8	16	8.5	5.2	B-PT1/8	11.6	
NRS 55RX NRS 55LRX	63	100	163.3 200.5	65	75 95	M12×18	123.6 160.8	17.7	49	16.6	10	16	10	5.2	B-PT1/8	14	
NRS 65RX NRS 65LRX	75	126	186 246	76	70 110	M16×20	143.6 203.6	21.6	60	19	15	16	8.7	8.2	B-PT1/8	15	
NRS 75R NRS 75LR	83	145	218 274	95	80 130	M18×25	170.2 226.2	25.3	68	18	17	16	9	8.2	B-PT1/8	15	
NRS 85R NRS 85LR	90	156	246.7 302.8	100	80 140	M18×25	194.9 251	27.3	73	20	20	16	10	8.2	B-PT1/8	17	
NRS 100R NRS 100LR	105	200	286.2 326.2	130	150 200	M18×27	223.4 263.4	34.3	85	23	23	10	12	8.2	B-PT1/4	20	

Model number coding

NRS45 LRX 2 QZ ZZHH C0 +1200L P T - II

Model number

Type of LM block

With QZ Lubricator

Contamination protection accessory symbol (*1)

LM rail length (in mm)

Symbol for LM rail jointed use

Symbol for No. of rails used on the same plane (*4)

No. of LM blocks used on the same rail

Radial clearance symbol (*2)
Normal (No symbol)/Light preload (C1)
Medium preload (C0)

Accuracy symbol (*3)

Normal grade (No Symbol)/High accuracy grade (H)
Precision grade (P)/Super precision grade (SP)
Ultra precision grade (UP)

(*1) See contamination protection accessory on **A1-516** (*2) See **A1-71**. (*3) See **A1-77**. (*4) See **A1-13**.

Note) This model number indicates that a single-rail unit constitutes one set. (i.e., required number of sets when 2 rails are used in parallel is 2 at a minimum.)

Those models equipped with QZ Lubricator cannot have a grease nipple. When desiring a grease nipple for a model attached with QZ, contact THK.

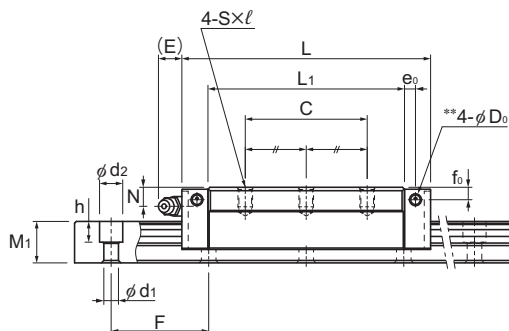

Model NRS-LRX

Unit: mm

LM rail dimensions						Basic load rating		Static permissible moment kN•m*					Mass	
Width W ₁ 0 -0.05	Height W ₂	Pitch M ₁	Pitch F	Length* d ₁ × d ₂ × h	Length* Max	C kN	C ₀ kN	M _A		M _B		M _C	LM block kg	LM rail kg/m
								1 block	Double blocks	1 block	Double blocks	1 block		
25	12.5	17	40	6×9.5×8.5	3000	28.4 34.7	52.2 69.6	0.457 0.786	2.43 3.9	0.422 0.727	2.25 3.61	0.552 0.732	0.4 0.5	2.9
28	16	21	80	7×11×9	3000	41.9 51.2	75.2 100.2	0.785 1.36	4.12 6.62	0.726 1.26	3.82 6.13	0.896 1.19	0.7 0.9	4.2
34	18	24.5	80	9×14×12	3000	55.5 68.6	95.5 129.5	1.09 1.95	5.88 9.61	1.01 1.81	5.45 8.9	1.36 1.84	1 1.3	6
45	20.5	29	105	14×20×17	3090	84.4 101.1	151.4 195.9	2.23 3.87	11.7 18.3	2.07 3.57	10.8 16.9	2.9 3.75	1.8 2.3	9.5
53	23.5	36.5	120	16×23×20	3060	108.7 134.1	191.6 259.3	3.36 5.76	17.4 28.4	3.1 5.32	16.1 26.3	4.19 5.67	3.3 4.3	14
63	31.5	43	150	18×26×22	3000	159.8 206	269.4 387.2	5.46 10.9	27.8 51.9	5.05 10.1	25.8 48	6.97 10.02	6 8.5	19.6
75	35	44	150	22×32×26	3000	212 278	431 566	10.6 18.6	53.8 87	10.6 18.6	53.8 87	13.4 17.6	8.7 11.6	24.6
85	35.5	48	180	24×35×28	3000	264 342	531 687	14.9 25.4	75.3 117	14.9 25.4	75.3 117	18.7 24.2	12.3 15.8	30.5
100	50	57	210	26×39×32	3000	376 470	737 920	25.1 34.6	123 174	25.1 34.6	123 174	30.4 38.1	21.8 26.1	42.6

Note1) The maximum length under "Length*" indicates the standard maximum length of an LM rail. (See [A1-240](#).)

Static permissible moment* 1 block: the static permissible moment with one LM block

Double blocks: static permissible moment when two LM blocks are in close contact with each other

For oil lubrication, be certain to let THK know the mounting orientation and where the LM block piping joint should be attached.

(Mounting orientation: see [A1-12](#), Lubricant: see [A24-2](#))

Total block length L

: The total block length L shown in the table is the length with the dust proof parts, code UU or SS. If other contamination protection accessories or lubricant equipment are installed, the total block length will increase.

(See [A1-491](#) or [A1-512](#))

** A pilot hole for side nipples, when a grease nipple for a model equipped with LaCS or QZ Lubricator is needed.

Pilot holes for side nipples are not drilled through for models other than those stated above.

For grease nipple mount machining, contact THK.

Note2) The basic load rating in the dimension table is for a load in the radial direction. Use Table7 on [A1-59](#) to calculate the load rating for loads in the reverse radial direction or lateral direction.

Models NR-CX and NR-LCX

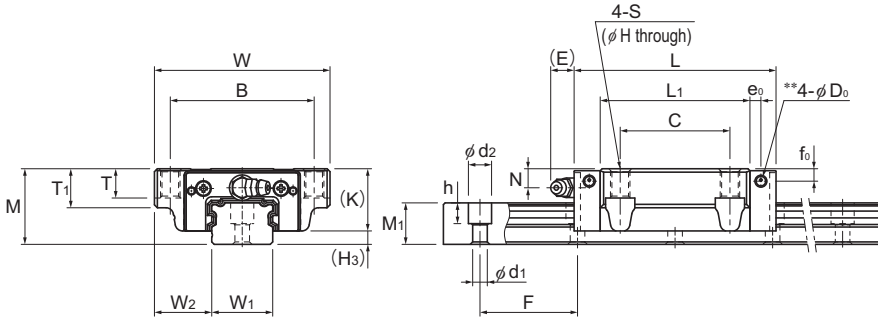

Model NR-CX

Model No.	Outer dimensions			LM block dimensions														Grease nipple	H ₃
	Height	Width	Length	B	C	S	H	L ₁	T	T ₁	K	N	f ₀	E	e ₀	D ₀			
	M	W	L	B	C	S	H	L ₁	T	T ₁	K	N	f ₀	E	e ₀	D ₀			
NR 25CX NR 25LCX	31	72	82.8 102	59	45	M8	6.8	61.4 80.6	14.8	16	25.5	7.8	5.1	12	4.5	3.9	B-M6F	5.5	
NR 30CX NR 30LCX	38	90	98 120.5	72	52	M10	8.5	72.1 94.6	16.9	18.1	31	10.3	7	12	6.5	3.9	B-M6F	7	
NR 35CX NR 35LCX	44	100	109.5 135	82	62	M10	8.5	79 104.5	18.9	20.1	35	12.1	8	12	6	5.2	B-M6F	9	
NR 45CX NR 45LCX	52	120	138.2 171	100	80	M12	10.5	105 137.8	20.6	22.1	40.4	13.9	8	16	8.5	5.2	B-PT1/8	11.6	
NR 55CX NR 55LCX	63	140	163.3 200.5	116	95	M14	12.5	123.6 160.8	22.5	24	49	16.6	10	16	10	5.2	B-PT1/8	14	
NR 65CX NR 65LCX	75	170	186 246	142	110	M16	14.5	143.6 203.6	26	28	60	19	15	16	8.7	8.2	B-PT1/8	15	

Model number coding

NR35	CX	2	QZ	KKHH	C0	+1400L	P	T	- II
Model number	Type of LM block	No. of LM blocks used on the same rail	With QZ Lubricator	Contamination protection accessory symbol (*1)	Radial clearance symbol (*2) Normal (No symbol) Light preload (C1) Medium preload (C0)	LM rail length (in mm)	Accuracy symbol (*3) Normal grade (No Symbol)/High accuracy grade (H) Precision grade (P)/Super precision grade (SP) Ultra precision grade (UP)	Symbol for LM rail jointed use	Symbol for No. of rails used on the same plane (*4)

(*1) See contamination protection accessory on **A1-516** (*2) See **A1-71**. (*3) See **A1-77**. (*4) See **A1-13**.

Note) This model number indicates that a single-rail unit constitutes one set. (i.e., required number of sets when 2 rails are used in parallel is 2 at a minimum.)

Those models equipped with QZ Lubricator cannot have a grease nipple. When desiring a grease nipple for a model attached with QZ, contact THK.

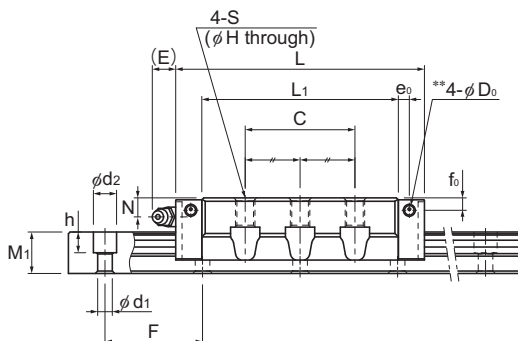

Model NR-LCX

Unit: mm

LM rail dimensions						Basic load rating		Static permissible moment $\text{kN}\cdot\text{m}^*$					Mass	
Width W_1 0-0.05	Height M_1	Pitch F	Pitch F	Length* $d_1 \times d_2 \times h$	Length* Max	C kN	C_0 kN	M_A		M_B		M_C	LM block	LM rail
								1 block	Double blocks	1 block	Double blocks	1 block	kg	kg/m
25	23.5	17	40	$6 \times 9.5 \times 8.5$	3000	37.1 45.4	68.1 90.8	0.57 0.989	3.04 4.91	0.346 0.597	1.84 2.95	0.703 0.937	0.6 0.8	2.9
28	31	21	80	$7 \times 11 \times 9$	3000	54.7 66.9	98.1 130.8	0.986 1.71	5.17 8.34	0.599 1.03	3.13 5.02	1.15 1.53	1.1 1.5	4.2
34	33	24.5	80	$9 \times 14 \times 12$	3000	72.4 89.6	124.6 169.1	1.37 2.46	7.38 12.1	0.835 1.49	4.48 7.3	1.74 2.36	1.6 2	6
45	37.5	29	105	$14 \times 20 \times 17$	3090	110.2 132	197.6 255.8	2.81 4.87	14.7 23	1.72 2.94	8.95 13.8	3.72 4.81	2.7 3.6	9.5
53	43.5	36.5	120	$16 \times 23 \times 20$	3060	141.9 175.1	250.2 338.4	4.22 7.27	21.8 35.9	2.56 4.4	13.2 21.7	5.37 7.27	4.5 5.9	14
63	53.5	43	150	$18 \times 26 \times 22$	3000	208.7 268.9	351.7 505.5	6.87 13.8	35 65.4	4.16 8.31	21.2 39.3	8.94 12.9	7.8 11	19.6

Note1) The maximum length under "Length*" indicates the standard maximum length of an LM rail. (See [A1-240](#).)

Static permissible moment* 1 block: the static permissible moment with one LM block

Double blocks: static permissible moment when two LM blocks are in close contact with each other

For oil lubrication, be certain to let THK know the mounting orientation and where the LM block piping joint should be attached.

(Mounting orientation: see [A1-12](#), Lubricant: see [A24-2](#))

Total block length L

: The total block length L shown in the table is the length with the dust proof parts, code UU or SS.

If other contamination protection accessories or lubricant equipment are installed, the total block length will increase.

(See [A1-491](#) or [A1-512](#))

** A pilot hole for side nipples, when a grease nipple for a model equipped with LaCS or QZ Lubricator is needed.

Pilot holes for side nipples are not drilled through for models other than those stated above.

For grease nipple mount machining, contact THK.

Note2) The basic load rating in the dimension table is for a load in the radial direction. Use Table7 on [A1-59](#) to calculate the load rating for loads in the reverse radial direction or lateral direction.

Models NRS-CX and NRS-LCX

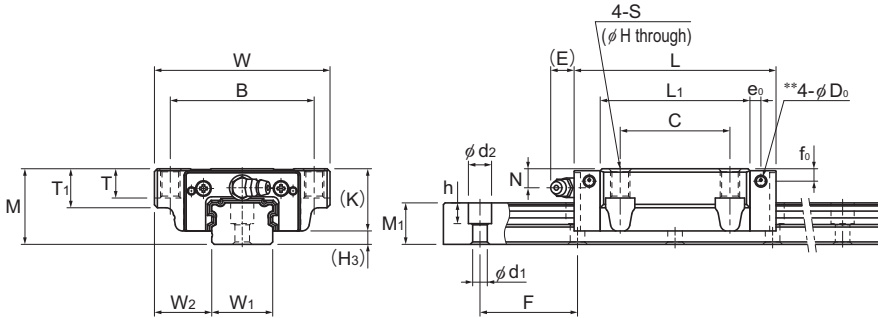

Model NRS-CX

Model No.	Outer dimensions			LM block dimensions														Grease nipple	H ₃
	Height	Width	Length	B	C	S	H	L ₁	T	T ₁	K	N	f ₀	E	e ₀	D ₀			
	M	W	L	B	C	S	H	L ₁	T	T ₁	K	N	f ₀	E	e ₀	D ₀			
NRS 25CX NRS 25LCX	31	72	82.8 102	59	45	M8	6.8	61.4 80.6	14.8	16	25.5	7.8	5.1	12	4.5	3.9	B-M6F	5.5	
NRS 30CX NRS 30LCX	38	90	98 120.5	72	52	M10	8.5	72.1 94.6	16.9	18.1	31	10.3	7	12	6.5	3.9	B-M6F	7	
NRS 35CX NRS 35LCX	44	100	109.5 135	82	62	M10	8.5	79 104.5	18.9	20.1	35	12.1	8	12	6	5.2	B-M6F	9	
NRS 45CX NRS 45LCX	52	120	138.2 171	100	80	M12	10.5	105 137.8	20.6	22.1	40.4	13.9	8	16	8.5	5.2	B-PT1/8	11.6	
NRS 55CX NRS 55LCX	63	140	163.3 200.5	116	95	M14	12.5	123.6 160.8	22.5	24	49	16.6	10	16	10	5.2	B-PT1/8	14	
NRS 65CX NRS 65LCX	75	170	186 246	142	110	M16	14.5	143.6 203.6	26	28	60	19	15	16	8.7	8.2	B-PT1/8	15	

Model number coding

NRS45 LCX 2 QZ SSHH C0 +2040L P T - II

Model number

Type of LM block

With QZ Lubricator

Contamination protection accessory symbol (*1)

LM rail length (in mm)

Symbol for LM rail jointed use

Symbol for No. of rails used on the same plane (*4)

No. of LM blocks used on the same rail

Radial clearance symbol (*2)
Normal (No symbol)
Light preload (C1)
Medium preload (C0)

Accuracy symbol (*3)
Normal grade (No Symbol)/High accuracy grade (H)
Precision grade (P)/Super precision grade (SP)
Ultra precision grade (UP)

(*1) See contamination protection accessory on **A1-516** (*2) See **A1-71**. (*3) See **A1-77**. (*4) See **A1-13**.

Note) This model number indicates that a single-rail unit constitutes one set. (i.e., required number of sets when 2 rails are used in parallel is 2 at a minimum.)

Those models equipped with QZ Lubricator cannot have a grease nipple. When desiring a grease nipple for a model attached with QZ, contact THK.

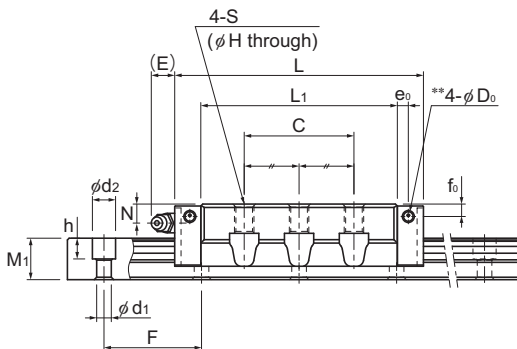

Model NRS-LCX

Unit: mm

LM rail dimensions						Basic load rating		Static permissible moment kN•m*					Mass	
Width W ₁ 0-0.05	Height W ₂	Pitch M ₁	Pitch F	Length* d ₁ × d ₂ × h	Length* Max	C kN	C ₀ kN	M _A		M _B		M _C	LM block	LM rail
								1 block	Double blocks	1 block	Double blocks	1 block	kg	kg/m
25	23.5	17	40	6 × 9.5 × 8.5	3000	28.4 34.7	52.2 69.6	0.457 0.786	2.43 3.9	0.422 0.727	2.25 3.61	0.552 0.732	0.6 0.8	2.9
28	31	21	80	7 × 11 × 9	3000	41.9 51.2	75.2 100.2	0.785 1.36	4.12 6.62	0.726 1.26	3.82 6.13	0.896 1.19	1.1 1.5	4.2
34	33	24.5	80	9 × 14 × 12	3000	55.5 68.6	95.5 129.5	1.09 1.95	5.88 9.61	1.01 1.81	5.45 8.9	1.36 1.84	1.6 2	6
45	37.5	29	105	14 × 20 × 17	3000	84.4 101.1	151.4 195.9	2.23 3.87	11.7 18.3	2.07 3.57	10.8 16.9	2.9 3.75	2.7 3.6	9.5
53	43.5	36.5	120	16 × 23 × 20	3000	108.7 134.1	191.6 259.3	3.36 5.76	17.4 28.4	3.1 5.32	16.1 26.3	4.19 5.67	4.5 5.9	14
63	53.5	43	150	18 × 26 × 22	3000	159.8 206	269.4 387.2	5.46 10.9	27.8 51.9	5.05 10.1	25.8 48	6.97 10.02	7.8 11	19.6

Note1) The maximum length under "Length*" indicates the standard maximum length of an LM rail. (See [A1-240](#).)

Static permissible moment* 1 block: the static permissible moment with one LM block

Double blocks: static permissible moment when two LM blocks are in close contact with each other

For oil lubrication, be certain to let THK know the mounting orientation and where the LM block piping joint should be attached.

(Mounting orientation: see [A1-12](#), Lubricant: see [A24-2](#))

Total block length L

: The total block length L shown in the table is the length with the dust proof parts, code UU or SS.

If other contamination protection accessories or lubricant equipment are installed, the total block length will increase.

(See [A1-491](#) or [A1-512](#))

** A pilot hole for side nipples, when a grease nipple for a model equipped with LaCS or QZ Lubricator is needed.

Pilot holes for side nipples are not drilled through for models other than those stated above.

For grease nipple mount machining, contact THK.

Note2) The basic load rating in the dimension table is for a load in the radial direction. Use Table7 on [A1-59](#) to calculate the load rating for loads in the reverse radial direction or lateral direction.

Models NR-A, NR-LA, NRS-A and NRS-LA

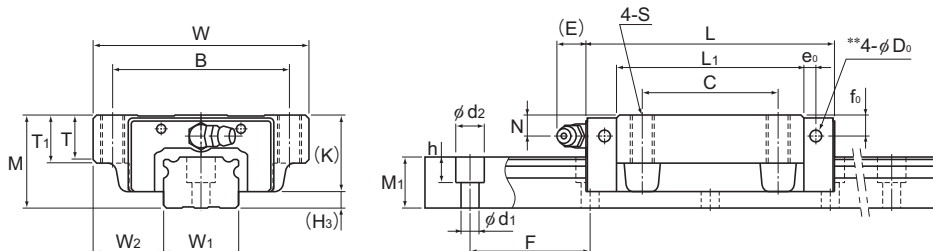

Models NR-A and NRS-A

Model No.	Outer dimensions			LM block dimensions														Grease nipple	H ₃
	Height	Width	Length	B	C	S × ℓ	L ₁	T	T ₁	K	N	f ₀	E	e ₀	D ₀				
	M	W	L																
NR 75A NR 75LA	83	195	218 274	165	130	M18×30	170.2 226.2	28	30	68	18	17	16	9	8.2	B-PT1/8	15		
NR 85A NR 85LA	90	215	246.7 302.8	185	140	M20×34	194.9 251	32	34	73	20	20	16	10	8.2	B-PT1/8	17		
NR 100A NR 100LA	105	260	286.2 326.2	220	150 200	M20×38	223.4 263.4	35	38	85	23	23	10	12	8.2	B-PT1/4	20		
NRS 75A NRS 75LA	83	195	218 274	165	130	M18×30	170.2 226.2	28	30	68	18	17	16	9	8.2	B-PT1/8	15		
NRS 85A NRS 85LA	90	215	246.7 302.8	185	140	M20×34	194.9 251	32	34	73	20	20	16	10	8.2	B-PT1/8	17		
NRS 100A NRS 100LA	105	260	286.2 326.2	220	150 200	M20×38	223.4 263.4	35	38	85	23	23	10	12	8.2	B-PT1/4	20		

Model number coding

NR75 A 2 QZ KKHH C0 +1400L P Z T - II

Model number

Type of LM block

With QZ Lubricator

Contamination protection accessory symbol (*1)

LM rail length (in mm)

Symbol for LM rail jointed use
With plate cover or steel tape (*4)

Symbol for No. of rails used on the same plane (*5)

No. of LM blocks used on the same rail

Radial clearance symbol (*2)
Normal (No symbol)
Light preload (C1)
Medium preload (C0)Accuracy symbol (*3)
Normal grade (No Symbol)/High accuracy grade (H)
Precision grade (P)/Super precision grade (SP)
Ultra precision grade (UP)(*1) See contamination protection accessory on **A1-516**. (*2) See **A1-71**. (*3) See **A1-77**.(*4) Specify the plate cover or the steel tape. (*5) See **A1-13**.

Note) This model number indicates that a single-rail unit constitutes one set. (i.e., required number of sets when 2 rails are used in parallel is 2 at a minimum.)

Those models equipped with QZ Lubricator cannot have a grease nipple. When desiring a grease nipple for a model attached with QZ, contact THK.

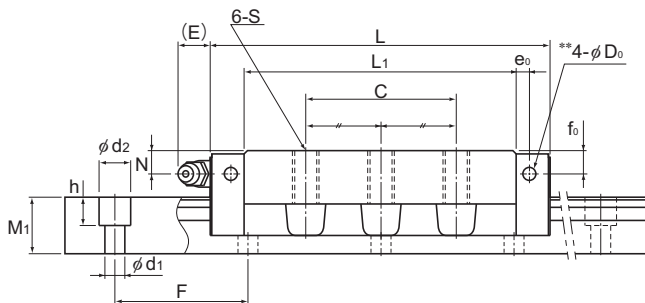

Models NR-LA and NRS-LA

Unit: mm

LM rail dimensions						Basic load rating		Static permissible moment $kN \cdot m^*$					Mass	
Width W_1 0 -0.05	Height M_1	Pitch F	Length* Max	$d_1 \times d_2 \times h$	C	C_0	M_A		M_B		M_C	LM block kg	LM rail kg/m	
							1 block	Double blocks	1 block	Double blocks	1 block			
75	60	44	150	$22 \times 32 \times 26$	3000	271 355	610 800	14.4 25.4	73.3 118	8.91 15.4	44.7 71.4	19.3 25.2	11.3 15	24.6
85	65	48	180	$24 \times 35 \times 28$	3000	336 435	751 972	20.3 34.7	102 160	12.4 21	62.6 96.2	26.8 34.6	16.2 20.7	30.5
100	80	57	210	$26 \times 39 \times 32$	3000	479 599	1040 1300	34 47.3	167 238	20.7 29.2	101 146	43.4 54.6	26.7 31.2	42.6
75	60	44	150	$22 \times 32 \times 26$	3000	212 278	431 566	10.6 18.6	53.8 87	10.6 18.6	53.8 87	13.4 17.6	11.3 15	24.6
85	65	48	180	$24 \times 35 \times 28$	3000	264 342	531 687	14.9 25.4	75.3 117	14.9 25.4	75.3 117	18.7 24.2	16.2 20.7	30.5
100	80	57	210	$26 \times 39 \times 32$	3000	376 470	737 920	25.1 34.6	123 174	25.1 34.6	123 174	30.4 38.1	26.7 31.2	42.6

Note1) The maximum length under "Length*" indicates the standard maximum length of an LM rail. (See [A1-240](#).)

Static permissible moment* 1 block: the static permissible moment with one LM block

Double blocks: static permissible moment when two LM blocks are in close contact with each other

For oil lubrication, be certain to let THK know the mounting orientation and where the LM block piping joint should be attached.

(Mounting orientation: see [A1-12](#), Lubricant: see [A24-2](#))

Total block length L

: The total block length L shown in the table is the length with the dust proof parts, code UU or SS. If other contamination protection accessories or lubricant equipment are installed, the total block length will increase.

(See [A1-491](#) or [A1-512](#))

** A pilot hole for side nipples, when a grease nipple for a model equipped with LaCS or QZ Lubricator is needed.

Pilot holes for side nipples are not drilled through for models other than those stated above.

For grease nipple mount machining, contact THK.

Note2) The basic load rating in the dimension table is for a load in the radial direction. Use Table7 on [A1-59](#) to calculate the load rating for loads in the reverse radial direction or lateral direction.

Models NR-B, NR-LB, NRS-B and NRS-LB

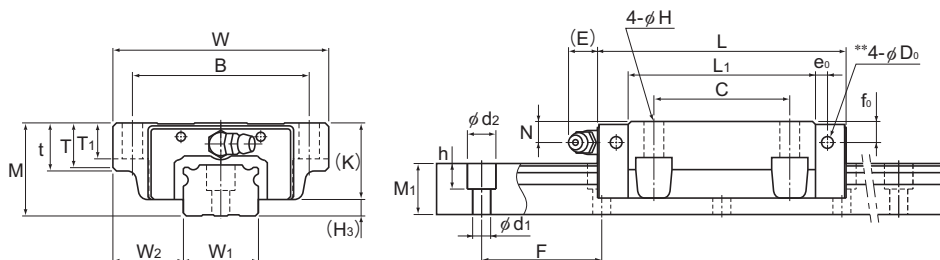

Models NR-B and NRS-B

Model No.	Outer dimensions			LM block dimensions																Grease nipple	H ₃
	Height	Width	Length	B	C	H	L ₁	t	T	T ₁	K	N	f ₀	E	e ₀	D ₀					
	M	W	L																		
NR 75B NR 75LB	83	195	218 274	165	130	18	170.2 226.2	30	28	26	68	18	17	16	9	8.2	B-PT1/8	15			
NR 85B NR 85LB	90	215	246.7 302.8	185	140	18	194.9 251	34	32	28	73	20	20	16	10	8.2	B-PT1/8	17			
NR 100B NR 100LB	105	260	286.2 326.2	220	150 200	20	223.4 263.4	38	35	32	85	23	23	10	12	8.2	B-PT1/4	20			
NRS 75B NRS 75LB	83	195	218 274	165	130	18	170.2 226.2	30	28	26	68	18	17	16	9	8.2	B-PT1/8	15			
NRS 85B NRS 85LB	90	215	246.7 302.8	185	140	18	194.9 251	34	32	28	73	20	20	16	10	8.2	B-PT1/8	17			
NRS 100B NRS 100LB	105	260	286.2 326.2	220	150 200	20	223.4 263.4	38	35	32	85	23	23	10	12	8.2	B-PT1/4	20			

Model number coding

NR75	B	2	QZ	DDHH	C0	+1080L	P	Z	T	-II
Model number	Type of LM block	No. of LM blocks used on the same rail	With QZ Lubricator	Contamination protection accessory symbol (*1)	Radial clearance symbol (*2) Normal (No symbol) Light preload (C1) Medium preload (C0)	LM rail length (in mm)	Accuracy symbol (*3) Normal grade (No Symbol)/High accuracy grade (H) Precision grade (P)/Super precision grade (SP) Ultra precision grade (UP)	Symbol for LM rail jointed use With plate cover or steel tape (*4)	Symbol for No. of rails used on the same plane (*5)	

(*1) See contamination protection accessory on **A1-516**. (*2) See **A1-71**. (*3) See **A1-77**.

(*4) Specify the plate cover or the steel tape. (*5) See **A1-13**.

Note) This model number indicates that a single-rail unit constitutes one set. (i.e., required number of sets when 2 rails are used in parallel is 2 at a minimum.)

Those models equipped with QZ Lubricator cannot have a grease nipple. When desiring a grease nipple for a model attached with QZ, contact THK.

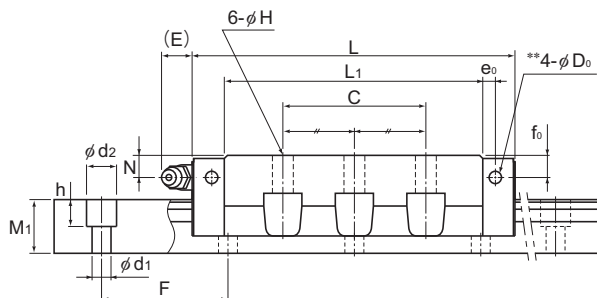

Models NR-LB and NRS-LB

Unit: mm

LM rail dimensions						Basic load rating		Static permissible moment kN•m*					Mass	
Width W ₁ 0 -0.05	W ₂	Height M ₁	Pitch F	d ₁ × d ₂ × h	Length* Max	C kN	C ₀ kN	M _A		M _B		M _C	LM block kg	LM rail kg/m
								1 block	Double blocks	1 block	Double blocks	1 block		
75	60	44	150	22 × 32 × 26	3000	271 355	610 800	14.4 25.4	73.3 118	8.91 15.4	44.7 71.4	19.3 25.2	11.3 15	24.6
85	65	48	180	24 × 35 × 28	3000	336 435	751 972	20.3 34.7	102 160	12.4 21	62.6 96.2	26.8 34.6	16.2 20.7	30.5
100	80	57	210	26 × 39 × 32	3000	479 599	1040 1300	34 47.3	167 238	20.7 29.2	101 146	43.4 54.6	26.7 31.2	42.6
75	60	44	150	22 × 32 × 26	3000	212 278	431 566	10.6 18.6	53.8 87	10.6 18.6	53.8 87	13.4 17.6	11.3 15	24.6
85	65	48	180	24 × 35 × 28	3000	264 342	531 687	14.9 25.4	75.3 117	14.9 25.4	75.3 117	18.7 24.2	16.2 20.7	30.5
100	80	57	210	26 × 39 × 32	3000	376 470	737 920	25.1 34.6	123 174	25.1 34.6	123 174	30.4 38.1	26.7 31.2	42.6

Note1) The maximum length under "Length*" indicates the standard maximum length of an LM rail. (See [A1-240](#).)

Static permissible moment* 1 block: the static permissible moment with one LM block

Double blocks: static permissible moment when two LM blocks are in close contact with each other

For oil lubrication, be certain to let THK know the mounting orientation and where the LM block piping joint should be attached.

(Mounting orientation: see [A1-12](#), Lubricant: see [A24-2](#))

Total block length L

: The total block length L shown in the table is the length with the dust proof parts, code UU or SS. If other contamination protection accessories or lubricant equipment are installed, the total block length will increase.

(See [A1-491](#) or [A1-512](#))

** A pilot hole for side nipples, when a grease nipple for a model equipped with LaCS or QZ Lubricator is needed.

Pilot holes for side nipples are not drilled through for models other than those stated above.

For grease nipple mount machining, contact THK.

Note2) The basic load rating in the dimension table is for a load in the radial direction. Use Table7 on [A1-59](#) to calculate the load rating for loads in the reverse radial direction or lateral direction.

Standard Length and Maximum Length of the LM Rail

Table1 shows the standard lengths and the maximum lengths of models NR/NRS-X variations. If the maximum length of the desired LM rail exceeds them, jointed rails will be used. Contact THK for details. For special rail lengths, it is recommended to use a value corresponding to the G,g dimension from the table. As the G,g dimension increases, this portion becomes less stable, and the accuracy performance is severely impacted.

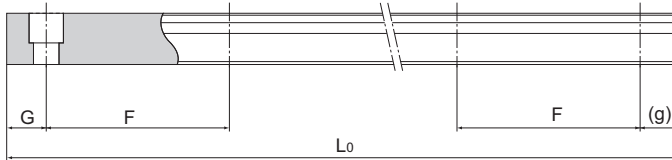

Table1 Standard Length and Maximum Length of the LM Rail for Models NR/NRS-X

Unit: mm

Model No.	NR/NRS25X	NR/NRS30X	NR/NRS35X	NR/NRS45X	NR/NRS55X	NR/NRS65X	NR/NRS75	NR/NRS85	NR/NRS100
	230	280	280	570	780	1270	1280	1530	1340
	270	360	360	675	900	1570	1580	1890	1760
	350	440	440	780	1020	2020	2030	2250	2180
	390	520	520	885	1140	2620	2630	2610	2600
	470	600	600	990	1260				
	510	680	680	1095	1380				
	590	760	760	1200	1500				
	630	840	840	1305	1620				
	710	920	920	1410	1740				
	750	1000	1000	1515	1860				
	830	1080	1080	1620	1980				
	950	1160	1160	1725	2100				
	990	1240	1240	1830	2220				
	1070	1320	1320	1935	2340				
	1110	1400	1400	2040	2460				
	1190	1480	1480	2145	2580				
	1230	1560	1560	2250	2700				
	1310	1640	1640	2355	2820				
	1350	1720	1720	2460	2940				
	1430	1800	1800	2565	3060				
	1470	1880	1880	2670					
	1550	1960	1960	2775					
	1590	2040	2040	2880					
	1710	2200	2200	2985					
	1830	2360	2360	3090					
	1950	2520	2520						
	2070	2680	2680						
	2190	2840	2840						
	2310	3000	3000						
	2430								
	2470								
Standard pitch F	40	80	80	105	120	150	150	180	210
G,g	15	20	20	22.5	30	35	40	45	40
Max length	3000	3000	3000	3090	3060	3000	3000	3000	3000

Note1) The maximum length varies with accuracy grades. Contact THK for details.

Note2) If jointed rails are not allowed and a greater length than the maximum values above is required, contact THK.

