

# RSR

## LM Guide Miniature Types Model RSR

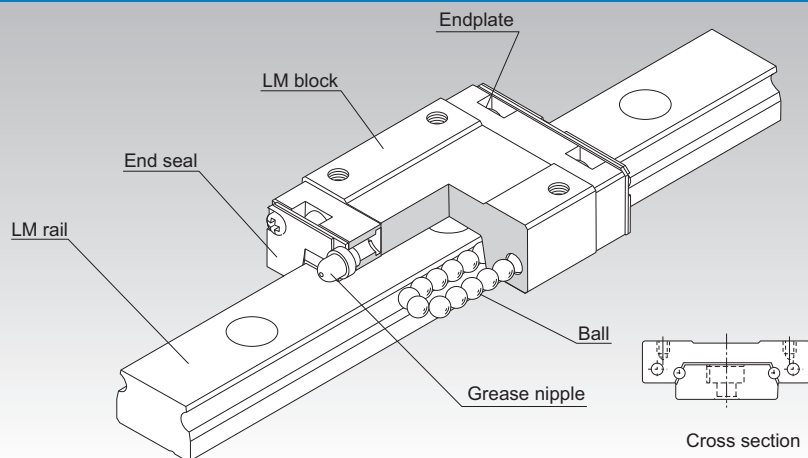

**Point of Selection** **A1-10**

**Point of Design** **A1-454**

**Options** **A1-477**

**Model No.** **A1-543**

**Precautions on Use** **A1-549**

**Accessories for Lubrication** **A24-1**

**Mounting Procedure and Maintenance** **B1-89**

Equivalent moment factor **A1-43**

Rated Loads in All Directions **A1-59**

Equivalent factor in each direction **A1-61**

Radial Clearance **A1-72**

Accuracy Standards **A1-83**

Shoulder Height of the Mounting Base and the Corner Radius **A1-469**

Permissible Error of the Mounting Surface **A1-471**

Flatness of the Mounting Surface **A1-472**

Dimensions of Each Model with an Option Attached **A1-491**

---

## Structure and Features

---

With models RSR and RSR-W, balls roll in two rows of raceways precision-ground on an LM rail and an LM block, and endplates incorporated in the LM block allow the balls to circulate. Since balls circulate in a compact structure, the LM Block is able to provide infinite straight motion and thus infinite stroke.

The LM block is designed to have a shape with high rigidity in a limited space, and in combination with large-diameter balls, demonstrates high rigidity in all directions.

### [Ultra-Compact]

The absence of cage displacement, a problem that cross-roller guides and types of ball slides with finite stroke tend to cause, make these models highly reliable LM systems.

### [Capable of Receiving a Load in Any Direction]

These models are capable of receiving loads in all directions, and a single-rail guide can adequately operate under a small moment load. Model RSR-W, in particular, has a greater number of effective balls and a broader LM rail to increase its rigidity against a moment. Thus, it achieves a more compact structure and more durable straight motion than a pair of linear bushes in parallel use.

### [Stainless Steel Type also Available]

A special type where LM block, LM rail and balls are made of stainless steel is also available.

## Types and Features

### Model RSR-M

Specification Table⇒ **A1-268**

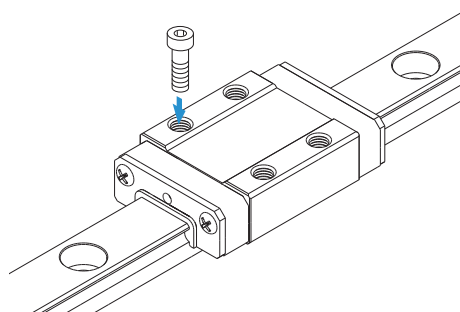

### Models RSR-WM/WVM

These models have greater overall LM block lengths (L), broader widths (W) and greater rated loads and permissible moments than standard types.

Specification Table⇒ **A1-268**

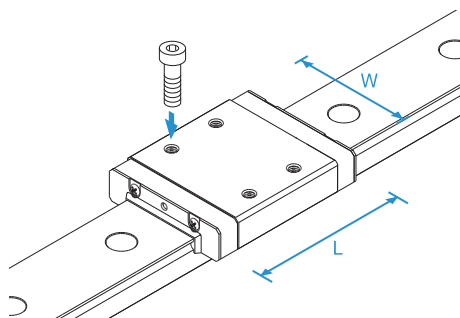

### Model RSR-N

It has a longer overall LM block length (L) and a greater rated load than standard types.

Specification Table⇒ **A1-268**

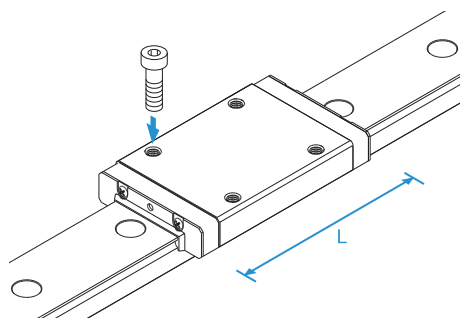

## Model RSR-WN

It has a longer overall LM block length (L), a greater rated load than standard types. Achieves the greatest load capacity among the miniature type LM Guide models.

Specification Table → **A1-268**

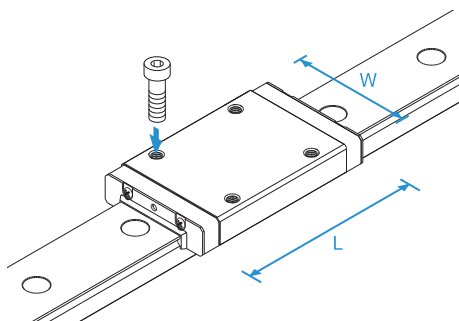

LM Guide

---

## Accuracy of the Mounting Surface

---

Model RSR uses Gothic arch grooves in the ball raceways. When two rails of RSR are used in parallel, any error in accuracy of the mounting surface may increase rolling resistance and negatively affect the smooth motion of the guide. For specific accuracy of the mounting surface, see [Flatness of the Mounting Surface] on **A1-472**.



# Models RSR-M, RSR-N, RSR-WM, RSR-WN and RSR-WVM

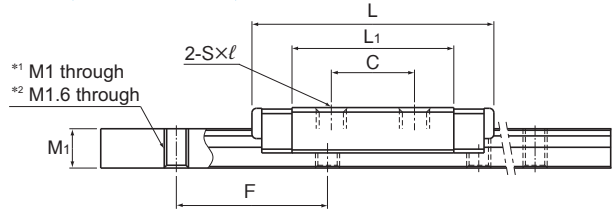
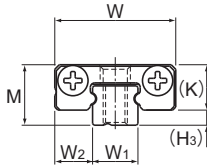

Models RSR2N, RSR3N

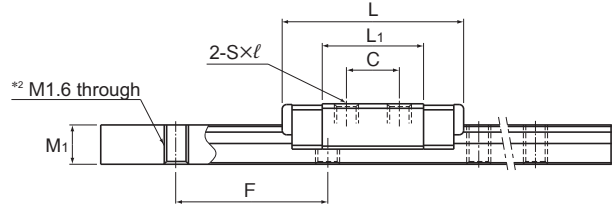
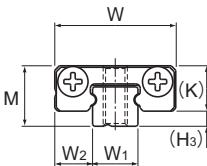

Model RSR3M

Model No.	Outer dimensions			LM block dimensions											H <sub>s</sub>
	Height	Width	Length	B	C	S × l	L <sub>1</sub>	T	K	N	E	Greasing hole d	Grease nipple		
	M	W	L												
RSR 2N RSR 2WN	3.2 4	6 10	12.4 16.7	—	4 6.5	M1.4 × 1.1 M2 × 1.3	8.84 11.9	—	2.5 3	—	—	—	—	0.7 1	
RSR 3M RSR 3N	4	8	12 16	—	3.5 5.5	M1.6 × 1.3 M2 × 1.3	6.7 10.7	—	3	—	—	—	—	1	
RSR 3WM RSR 3WN	4.5	12	14.9 19.9	—	4.5 8	M2 × 1.7	8.5 13.3	—	3.5	0.8	—	0.8	—	1	
RSR 14WVM	15	50	50	35	18	M4 × 4.5	34.3	6	11.5	3	4	—	PB107	3.5	

Note) Models RSR2 and 3 do not have an oil hole. When lubricating them, apply a lubricant directly to the LM rail raceways.  
No contamination protection seal for RSR2N/2WN/3M/3N.

## Model number coding

**2 RSR3W M UU C1 +80L P M - II**

2: No. of LM blocks used on the same rail (\*1)  
 RSR3W M: Model number  
 UU: Contamination protection accessory symbol (\*2)  
 C1: Radial clearance symbol (\*3)  
 +80L: LM rail length (in mm)  
 P: Accuracy symbol (\*4)  
 M: Stainless steel LM rail  
 - II: Symbol for No. of rails used on the same plane (\*5)

(\*1) No symbol for 1 LM block. (\*2) See contamination protection accessories on **A1-516**.

(\*3) See **A1-72**. (\*4) See **A1-83**. (\*5) See **A1-13**.

Note) This model number indicates that a single-rail unit constitutes one set. (i.e., required number of sets when 2 rails are used in parallel is 2 at a minimum.)

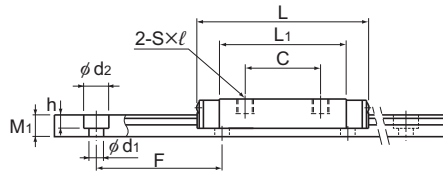
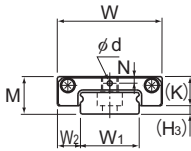

Models RSR2WN, RSR3WM/WN

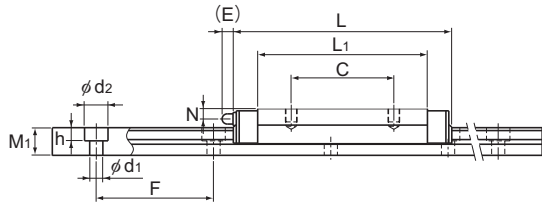
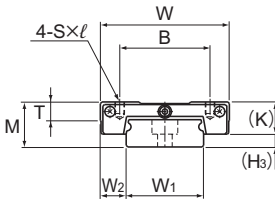

Model RSR14WVM

Unit: mm

	LM rail dimensions						Basic load rating		Static permissible moment $N \cdot m^*$					Mass		
	Width		Height		Pitch	Length*	C	$C_0$	$M_A$		$M_B$		$M_C$	LM block	LM rail	
	$W_1$	$W_2$	$M_1$	F	$d_1 \times d_2 \times h$				1 block	Double blocks	1 block	Double blocks	1 block			
	$W_1$	$W_2$	$M_1$	F	$d_1 \times d_2 \times h$	Max	kN	kN						kg	kg/m	
	2 4	0 -0.03	2 3	2 2.6	8 10	— <sup>1</sup> 1.8×2.8×0.75	200	0.214 0.395	0.384 0.682	0.564 1.336	2.994 7.32	0.564 1.336	2.994 7.32	0.442 1.501	0.0008 0.0020	0.029 0.075
	3	0 -0.02	2.5	2.6	10	— <sup>2</sup>	220	0.18 0.3	0.27 0.44	0.293 0.726	2.11 4.33	0.293 0.726	2.11 4.33	0.45 0.73	0.0011 0.0016	0.055
	6	0 -0.02	3	2.6	15	2.4×4×1.5	335	0.25 0.39	0.47 0.75	0.668 1.57	4.44 9.06	0.668 1.57	4.44 90.6	1.48 2.36	0.002 0.003	0.12
	30	0 -0.05	10	9	40	4.5×7.5×5.3	1800	6.01	9.08	43.2	233	38.2	208	110	0.096	2

Note1) The maximum length under "Length\*" indicates the standard maximum length of an LM rail. (See [A1-270](#).)

Static permissible moment\* 1 block: the static permissible moment with one LM block

Double blocks: static permissible moment when two LM blocks are in close contact with each other

Total block length L

: The total block length L shown in the table is the length with the dust-proof parts (code: UU).

The M in the model number symbol indicates that the LM block, LM rail and balls are made of stainless steel.

The stainless steel provides excellent corrosion and environmental resistance.

Please be aware that balls will fall out if the LM block is removed from the LM rail.

Note2) The basic load rating in the dimension table is for a load in the radial direction. Use Table7 on [A1-59](#) to calculate the load rating for loads in the reverse radial direction or lateral direction.

### ● Recommended tightening torque when mounting the LM rail/block

Table1 shows recommended bolt tightening torques when mounting the LM block and LM rail of models RSR2 and RSR3.

Table1 Recommended Tightening Torques of Mounting Bolts

Model No.	Model No. of screw	Recommended tightening torque ( $N \cdot m$ )		Remarks
		Block	Rail	
RSR 2N	M1	0.09	0.03	Flathead machine screw designed for use with precision equipment
RSR 2WN	M1.6	0.28	0.138	
RSR 3M	M1.6	0.09	0.09	Austenite stainless steel hexagonal-socket-head type bolts
RSR 3N	M2	0.19	0.19	
RSR 3WM/3WN	M2	0.19	—	Cross-recessed head screws for precision equipment (No. 0 pan head screw, class 1)
		—	0.25	



## Standard Length and Maximum Length of the LM Rail

Table2 shows the standard and maximum lengths of the RSR model rail.

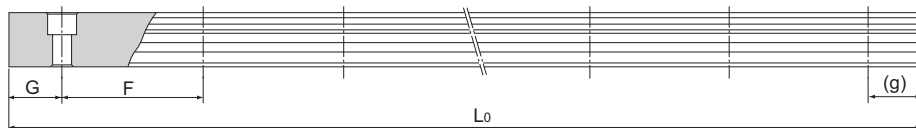

Table2 Standard Length and Maximum Length of the LM Rail for Model RSR/RSR-W

Unit: mm

Model No.	RSR2N	RSR2WN	RSR3	RSR3W	RSR14W
LM rail standard length (L <sub>0</sub> )	32	40	30	40	110
	40	60	40	55	150
	56	70	60	70	190
	80	80	80		230
	104	100	100		270
		180			310
					430
Standard pitch F	8	10	10	15	40
G,g	4	5	5	5	15
Max length	200	200	220	335	1800

Note1) The maximum length varies with accuracy grades. Contact THK for details.

Note2) The LM rail mounting hole of model RSR3 is an M1.6 through hole.

## Prevention of LM block from falling off of LM rail

In model RSR/RSR-W, the balls fall out if the LM block comes off the LM rail.

For this reason, LM Guide assemblies are delivered with a part which prevents the LM block from coming off the rail. If you remove this part when using the product, please take precautions to avoid overrunning the blocks off of the rail.

